



+48 32 74 99 225

# Turmdrehkran 40 LC

Tower Crane / Grue à tour  
Grúa torre / Guindaste de

# MAZUR

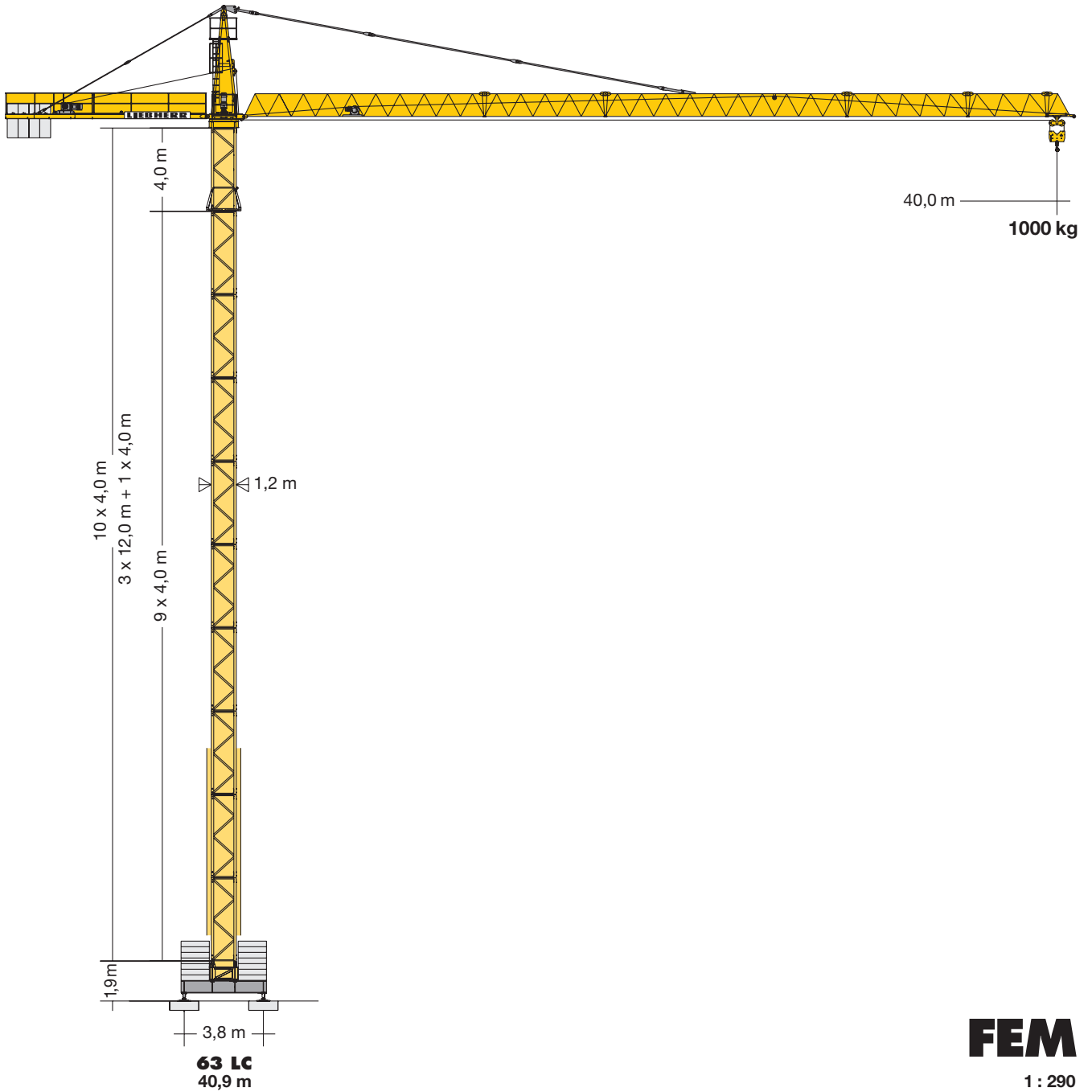

## FEM

1 : 290

# LIEBHERR

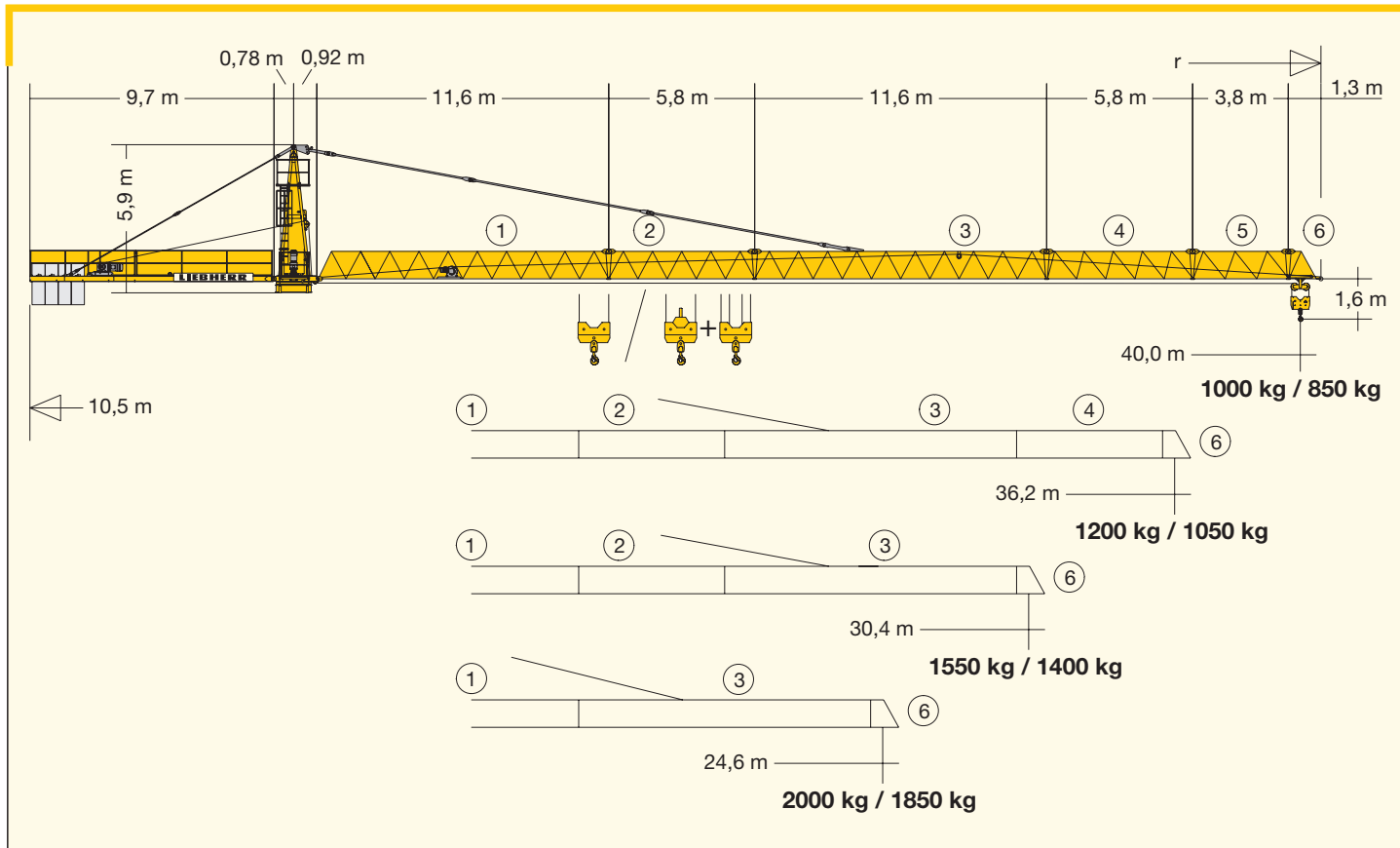

## Gewicht

Weight / Poids / Peso / Peso / Pesos

|   |          |   |              |         |   |          |
|---|----------|---|--------------|---------|---|----------|
| <b>Zentralballast</b> / Central ballast<br>Lest de base / Zavorra centrale<br>Lastro central / Lastre central | 50000 kg |  | (Ausl. 40 m) | 6600 kg |  | 19100 kg |
|---|----------|---|--------------|---------|---|----------|

## Hubhöhe

Hoisting height / Hauteur sous crochet / Altezza di sollevamento / Altura bajo gancho / Altura de montagem

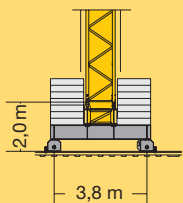
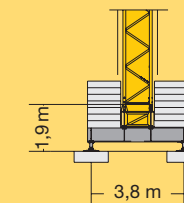
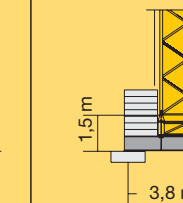
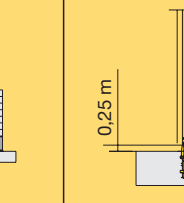
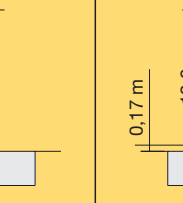
|     |      | 63 LC   |   |   |  |   |
|-----|------|---|---|---|--|---|
| 4 m | 12 m |   |   |   |  |   |
| 10  |      | –   | 40,9*   | 40,5*   | 39,3*  | –   |
| 9   | 3    | 37,0*   | 36,9*   | 36,5*   | 35,3*  | 47,1*   |
| 8   |      | 33,0  | 32,9  | 32,5  | 31,3   | 43,1*   |
| 7   |      | 29,0  | 28,9  | 28,5  | 27,3   | 39,1  |
| 6   | 2    | 25,0  | 24,9  | 24,5  | 23,3   | 35,1  |
| 5   |      | 21,0  | 20,9  | 20,5  | 19,3   | 31,1  |
| 4   |      | 17,0  | 16,9  | 16,5  | 15,3   | 27,1  |
| 3   | 1    | 13,0  | 12,9  | 12,5  | 11,3   | 23,1  |
| 2   |      | 9,0   | 8,9   | 8,5   | 7,3  | 19,1  |
| 1   |      | 5,0   | 4,9   | 4,5   | 3,3  | 15,1  |
| 0   |      |   |   |   |  | 11,1  |
|     |      | m   | m   | m   | m  | m   |
|     |      |  |  |  |  |  |



**Weitere Hubhöhen auf Anfrage.** / Further hoist heights on request. / Hauteurs sous crochet sur demande. / Altre altezze di sollevamento: su richiesta. / Outras alturas de elevação: conforme ao pedido. / Para alturas bajo gancho superiores, consultar.

\*\* nicht kletterbar / not for climbing / non télescopable / non telescopabile / no trepable / no telescopabel



# Ausladung und Tragfähigkeit

Radius and capacity / Portée et charge / Sbraccio e portata / Alcances y cargas / Alcance e capacidade de carga

| m    | r          | m/kg             | m/kg |      |      |      |      |      |      |      |      |      |      |      |
|------|------------|------------------|------|------|------|------|------|------|------|------|------|------|------|------|
|      |            |                  | 10,0 | 12,0 | 14,0 | 16,0 | 18,0 | 20,0 | 24,6 | 27,0 | 30,4 | 33,0 | 36,2 | 40,0 |
| 40,0 | (r = 40,9) | 2,1-18,7<br>2500 |      |      |      |      | 2500 | 2310 | 1810 | 1620 | 1400 | 1270 | 1130 | 1000 |
| 36,2 | (r = 37,1) | 2,1-19,5<br>2500 |      |      |      |      | 2500 | 2430 | 1900 | 1710 | 1480 | 1340 | 1200 |      |
| 30,4 | (r = 31,3) | 2,1-20,2<br>2500 |      |      |      |      | 2500 | 2500 | 1990 | 1780 | 1550 |      |      |      |
| 24,6 | (r = 25,5) | 2,1-20,3<br>2500 |      |      |      |      | 2500 | 2500 | 2000 |      |      |      |      |      |

| m    | r          | m/kg             | m/kg             |      |      |      |      |      |      |      |      |      |      |      |     |
|------|------------|------------------|------------------|------|------|------|------|------|------|------|------|------|------|------|-----|
|      |            |                  | 10,0             | 12,0 | 14,0 | 16,0 | 18,0 | 20,0 | 24,6 | 27,0 | 30,4 | 33,0 | 36,2 | 40,0 |     |
| 40,0 | (r = 40,9) | 2,1-17,7<br>2500 | 2,1-11,9<br>4000 | 4000 | 3980 | 3310 | 2820 | 2440 | 2150 | 1660 | 1470 | 1250 | 1120 | 980  | 850 |
| 36,2 | (r = 37,1) | 2,1-18,5<br>2500 | 2,1-12,4<br>4000 | 4000 | 4000 | 3490 | 2970 | 2580 | 2270 | 1750 | 1560 | 1330 | 1190 | 1050 |     |
| 30,4 | (r = 31,3) | 2,1-19,2<br>2500 | 2,1-12,7<br>4000 | 4000 | 4000 | 3630 | 3100 | 2690 | 2370 | 1850 | 1630 | 1400 |      |      |     |
| 24,6 | (r = 25,5) | 2,1-19,3<br>2500 | 2,1-12,7<br>4000 | 4000 | 4000 | 3630 | 3100 | 2690 | 2370 | 1850 |      |      |      |      |     |

## Antriebe

Driving units / Mécanismes d'entraînement / Azionamenti / Mecanismos / Mecanismos











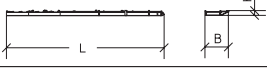

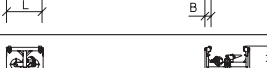

|  |  |  |
|--|--|--|
|  | U/min<br>0 - 0,8 sl./min<br>tr./min    | 1 x 5,0 kW EDC                               |
|  | 19,0 / 38,0 m/min<br>21,0 / 42,0 m/min | 1,0 / 1,8 kW<br>1,5 / 3,0 kW                 |
|  | 20,0 m/min                             | 2 x 2,2 kW                                   |
|  | <b>kVA</b>                             | 14,0 kW 14,0 kW FU 22,0 kW<br>29,0 21,0 38,0 |

|  |   | Stufe / Step<br>Cran / Marcia<br>Marcha / Marcha                  |      | kg        | m/min     |
|--|---|---|------|-----------|-----------|
|  | 3,2 / 14,0 / 14,0 kW<br>WIW 210 MZ 402                            | 4 <b>Lagen</b><br>Layers<br>Couches<br>Strati<br>Camadas<br>Capas | 1    | 2500      | 2500 6,2  |
|  |   |   | 2    | 2500      | 2500 27,0 |
|  |   |   | 3    | 1300      | 1200 54,0 |
|  | 6 <b>Lagen</b><br>Layers<br>Couches<br>Strati<br>Camadas<br>Capas | 1   | 2400 | 2300 6,5  |           |
|  |   | 2   | 2400 | 2300 28,5 |           |
|  |   | 3   | 1200 | 1100 57,0 |           |
|  | 5 <b>Lagen</b><br>Layers<br>Couches<br>Strati<br>Camadas<br>Capas | 1   | 2400 | 2300 8,2  |           |
|  |   | 2   | 2400 | 2300 38,0 |           |
|  |   | 3   | 1350 | 1250 76,0 |           |
|  | 14,0 kW FU<br>WIW 210 MZ 403                                      | 4 <b>Lagen</b><br>Layers<br>Couches<br>Strati<br>Camadas<br>Capas | 1    | 2500      | 2500 5,0  |
|  |   |   | 2    | 2500      | 2500 25,0 |
|  |   |   | 3    | 1900      | 1800 36,0 |
|  |   |   | 4    | 1300      | 1200 52,0 |
|  | 6 <b>Lagen</b><br>Layers<br>Couches<br>Strati<br>Camadas<br>Capas | 1   | 2500 | 2500 5,2  |           |
|  |   | 2   | 2500 | 2500 26,0 |           |
|  |   | 3   | 1750 | 1650 37,0 |           |
|  |   | 4   | 1200 | 1100 54,0 |           |
|  |   |   | 1    | 4000      | 2,6       |
|  |   |   | 2    | 4000      | 13,0      |
|  |   |   | 3    | 3500      | 18,5      |
|  |   |   | 4    | 2350      | 27,0      |

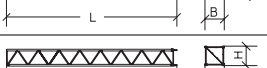
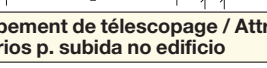

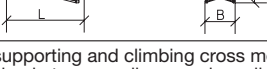
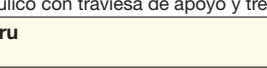
+48 32 74 99 225

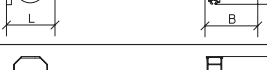
Montagewichte: siehe Betriebsanleitung. / Erection weights: see instruction manual. / Poids de montage: voir manuel de service. / Pesos di montaggio: vedasi le istruzioni sull'uso. / Pesos de montagem: vejã-se es instruções p. uso. / Peso para el montaje: según manual.

| <b>Kranoberteil</b>           |                      | Upper part of crane / Partie supérieure de grue / Parte superiore della gru<br>Parte superior grúa / Parte superior do guindaste   |   | L (m)                         | B (m)                        | H (m)                        | kg*                              |             |
|-------------------------------|----------------------|--|---|-------------------------------|------------------------------|------------------------------|----------------------------------|-------------|
| Pos. Item Rep. Voce Pos. Ref. | Anz. Qty. Qta. Cant. | <b>Turm Spitze mit Kud-Auflage</b><br>Tower head section with slewing ring support<br>Porte-flèche avec pivot / Testa porta-braccio con supporto ralla<br>Cabeça de apoia de lança / Cabeza de torre con asiento de pista  |    | 5,57                          | 1,86                         | 1,73                         | 2530                             |             |
| 1                             | 1                    |  |   |                               |                              |                              |                                  |             |
| 2                             | 1                    | <b>Gegenausleger</b> / Counter-jib<br>Contre-flèche / Contrabracchio<br>Contra-lança / Contrapluma   |    | 9,79                          | 1,46                         | 0,36                         | 960                              |             |
| 3                             | 1                    | <b>Ausleger-Anlenkstück</b> / Jib heel section<br>Pied de flèche / Settore articolato di braccio<br>Base articulada de lança / Pluma tramo primero   |    | 11,85                         | 1,04                         | 1,30                         | ① 950                            |             |
| 4                             | 1                    | <b>Ausleger-Zwischenstück</b> / Intermediate jib section<br>Elément intermédiaire de flèche / Spezzone di braccio<br>Peça suplementar da lança / Tramo intermedio pluma  |    | 5,94<br>11,80<br>5,94<br>3,94 | 0,95<br>0,95<br>0,95<br>0,95 | 1,22<br>1,32<br>1,22<br>1,22 | ② 336<br>③ 618<br>④ 210<br>⑤ 147 |             |
| 5                             | 1                    | <b>Ausleger-Kopfstück</b> / Jib head<br>Pointe de flèche / Punta freccia<br>Cabeça de lança / Tramo punta de pluma   |    | 1,45                          | 1,04                         | 1,37                         | ⑥ 80                             |             |
| 6                             | 1                    | <b>Podeste</b> / Platforms<br>Plates-formes / Plattaforma<br>Plataforma / Plataforma   |    | 1,21                          | 0,33                         | 0,77                         | 66                               |             |
| 7                             | 1                    | <b>Laufkatze</b> / Trolley<br>Chariot / Carrello<br>Carrinho / Carrito   |    | 0,95                          | 1,13                         | 0,62                         | 151                              |             |
| 8                             | 1                    | <b>Unterflasche</b> / Bottom<br>Moufle / Bozzello<br>Gancha / Potipasto  |    | 0,75                          | 0,24                         | 0,98                         | 104                              |             |
| 9                             | 1                    | <b>Hubwerk 11 kW</b> / Winch<br>Treuil / Argano / Mecanismo elevatoria<br>Mecanismo elevación carga  |   | 1,25                          | 1,23                         | 0,55                         | 440                              |             |
| <b>Turm</b>                   |                      | <b>Tower / Mât / Torre</b><br><b>Torre / Torre</b>   |   |                               |                              |                              |                                  |             |
| 10                            | 1                    | <b>Turmstück</b> / Tower section<br>Elément de mât / Elemento di torre<br>Torre / Torre  |  | 12,0 m<br>4,0 m               | 12,27<br>4,27                | 1,20<br>1,20                 | 1,20<br>1,30                     | 2435<br>958 |
| 11                            | 1                    | <b>Grundturmstück</b> / Base tower section<br>Mât de base / Elemento di torre base<br>Tramo torre base / Peça de base de torre   |  | 12,00                         | 1,42                         | 1,42                         | 3343                             |             |
| <b>Klettereinrichtung</b>     |                      | <b>Climbing equipment / Equipement de télescopage / Attrezzatura per allungamento della gru</b><br><b>Equipo de trepado / Acesórios p. subida no edificio</b>  |   |                               |                              |                              |                                  |             |
| 12                            | 1                    | <b>Führungsstück kpl.</b> / Guide section cpl.<br>Cage télescopique cpl. / Gabbia de sopraelevazione compl.<br>Peça de guia compl. / Torre de montaje completa   |  | 8,92                          | 1,65                         | 1,75                         | 1890                             |             |
| 13                            | 1                    | <b>KUD-Auflagenverlängerung</b> / Slewing ring support extension<br>Rehausse de pivot d'orientation / Prolunga supporto ralla<br>Peça de guia / Prolongación asiento de pista  |  | 4,27                          | 1,66                         | 1,66                         | 1120                             |             |
| 14                            | 1                    | <b>Hydraulikanlage, Stütz- und Klettertraverse</b> / Hydraulic unit, supporting and climbing cross members<br>Système hydraul. avec traverses d'appui el de télescop. / Sist. idraul., traversa di appoggio e allugam. gru<br>Instalação hidráulica, travessa de apoio e subida / Sistema hidráulico com travessa de apoio y trepade |  | 4,86                          | 0,95                         | 0,70                         | 580                              |             |
| <b>Unterwagen</b>             |                      | <b>Undercarriage / Châssis / Carro della gru</b><br><b>Carro con mástil / Carro de guindaste</b>   |   |                               |                              |                              |                                  |             |
| 15                            | 1                    | <b>Unterwagen-Rahmen</b> / Undercarriage frame<br>Cadre de châssis / Intelaiatura carro<br>Estrotura do carrinho / Bastidor carretón   |  | 4,12                          | 0,94                         | 1,39                         | 2575                             |             |
| 16                            | 2                    | <b>Tragholm</b> / Arm<br>Longeron / Longherone<br>Travessa / Brazo   |  | 4,10                          | 0,30                         | 0,60                         | 935                              |             |
| 17                            | 2                    | <b>Fahrschemel mit Antrieb</b> / Rail bogie with drive<br>Bogie moteur / Telajo con gruppa propulsore<br>Quadra sem grupa de propulsão / Caja rodillo motriz   |  | 0,78                          | 0,84                         | 0,53                         | 297                              |             |
| 18                            | 2                    | <b>Fahrschemel ohne Antrieb</b> / Rail bogie without drive<br>Bogie fou / Telajo senza gruppa propulsore<br>Quadra com grupa de propulsão / Caja rodillo conducido   |  | 0,66                          | 0,30                         | 0,51                         | 204                              |             |
| 19                            | -                    | <b>Seile und Kleinteile</b> / Small parts and ropes<br>Accessoire et câbles / Accessori cavi<br>Acessorios e cabos / Accesorios y cables   |   | -                             | -                            | -                            | 870                              |             |

\* Einzelgewichte. / Single weights. / Poids individuels. / Pesì di componenti. / Pesos de peças componentes. / Pesos unitarios.

### Konstruktionsänderungen vorbehalten!

Subject to alterations! / Sous réserves de modifications!  
Si fa riserva di modifiche! / Salvo modificação da construoão!  
¡Sujeto a modificaciones!

### Sämtliche Angaben erfolgen ohne Gewähr. / This information is supplied without liability.

Ces renseignements sont sans garantie. / Le indicazioni contenute si intendono salvo errori ed omissioni.  
Declinamos toda responsabilidad derivada de la información proporcionada. / Declinamos qualquer  
responsabilidade quanto à informação fornecida.

121 P – 3925 FEM (Section 1) Krangruppe A3 • 05.05 / 6

Printed in Germany.



+48 32 74 99 225